

风电模组—160V,7F

典型应用

风力变桨、储能系统、医疗设备应急后备电源等。

性能特点

规格	特性
额定电压	160 V.DC
浪涌电压	176V.DC
额定容量	7F
工作温度范围	-40°C ~ +65°C
产品寿命	常温循环寿命：在25°C下，用恒定电流使电容器在规格电压和半额定电压间循环充放电50万次。容量衰减≤30%，内阻变化≤3倍。
	高温耐久寿命：在+65°C条件下，施加额定电压1000小时。容量衰减≤30%，内阻变化≤3倍。

尺寸图示 (单位：mm)

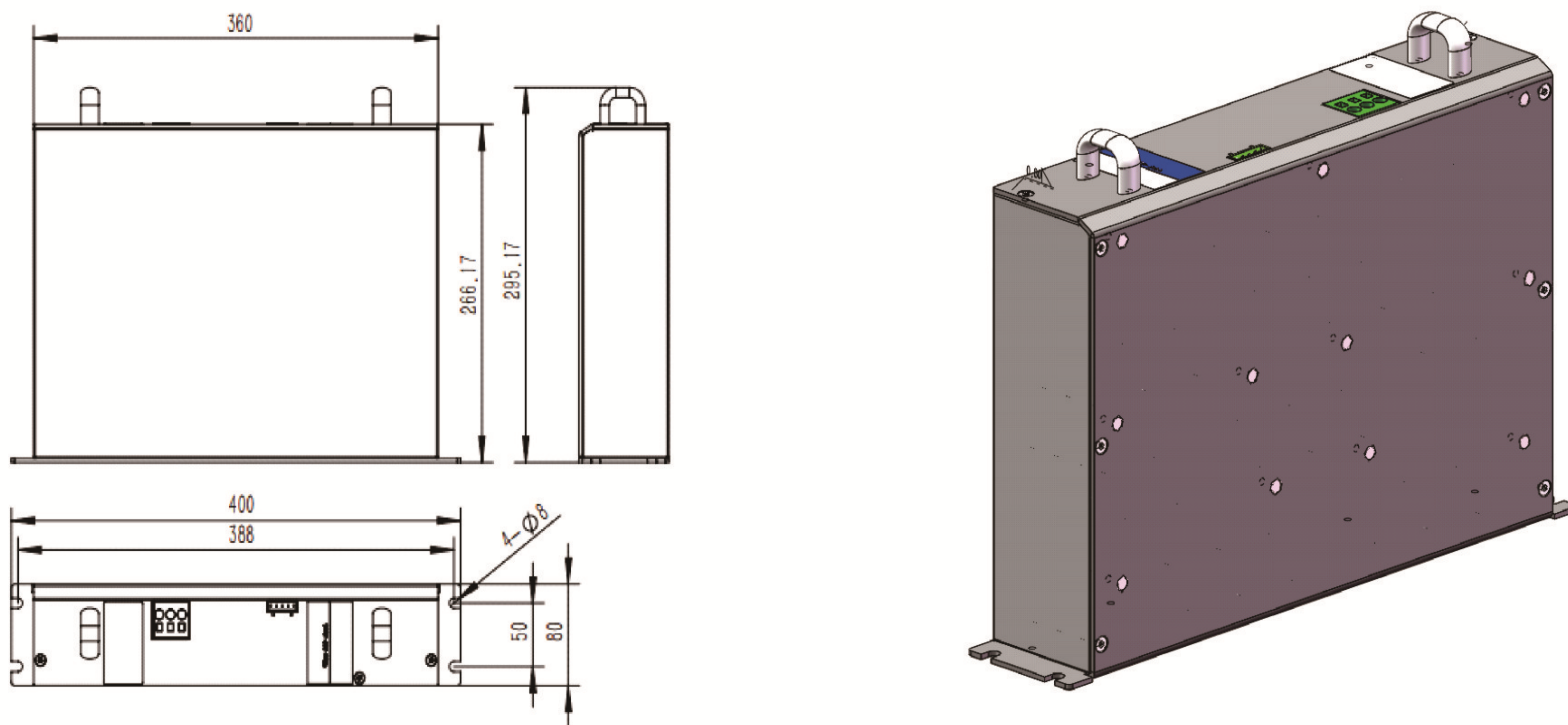

规格参数

产品编码	额定电压 (V)	标称容量 (F)	尺寸(mm)			内阻 ESRDC (25°C/mΩ)	最大工作电流(A)		最大峰值电流 (A)	最大漏电流 (72hrs/mA)	最大能量 (W.h)	能量密度 (W.h/kg)	功率密度 (KW/kg)
			长度 (L)	宽度 (W)	高度 (H)		(ΔT=15°C)	(ΔT=40°C)					
SMD0160R0007PAJZF00	160	7	400	80	295	196	16	27	250	30	28	4.1	2.6

WIND POWER MODULE - 160V,7F

Typical Applications

Variable wind power propellers, energy storage systems, Variable wind power propellers, energy storage systems, Emergency backup power supply for medical equipment, etc.

Features

Specifications	Characteristic
Rated voltage	160 V.DC
Surge voltage	176V.DC
Rated Capacity	7F
Operating temperature	-40°C~+65°C
Life	Cycle life at normal temperature: Capacitors charge- discharge between rated voltage & half voltage under constant current at 25°C.≥500,000 cycles,Capacity fade ≤30%, internal resistance variation ≤3 times
	High-temperature durability: Apply rated voltage for 1,000 hours at +65°C. Capacity fade ≤30%, internal resistance variation ≤3 times

Dimensions (Unit:mm)

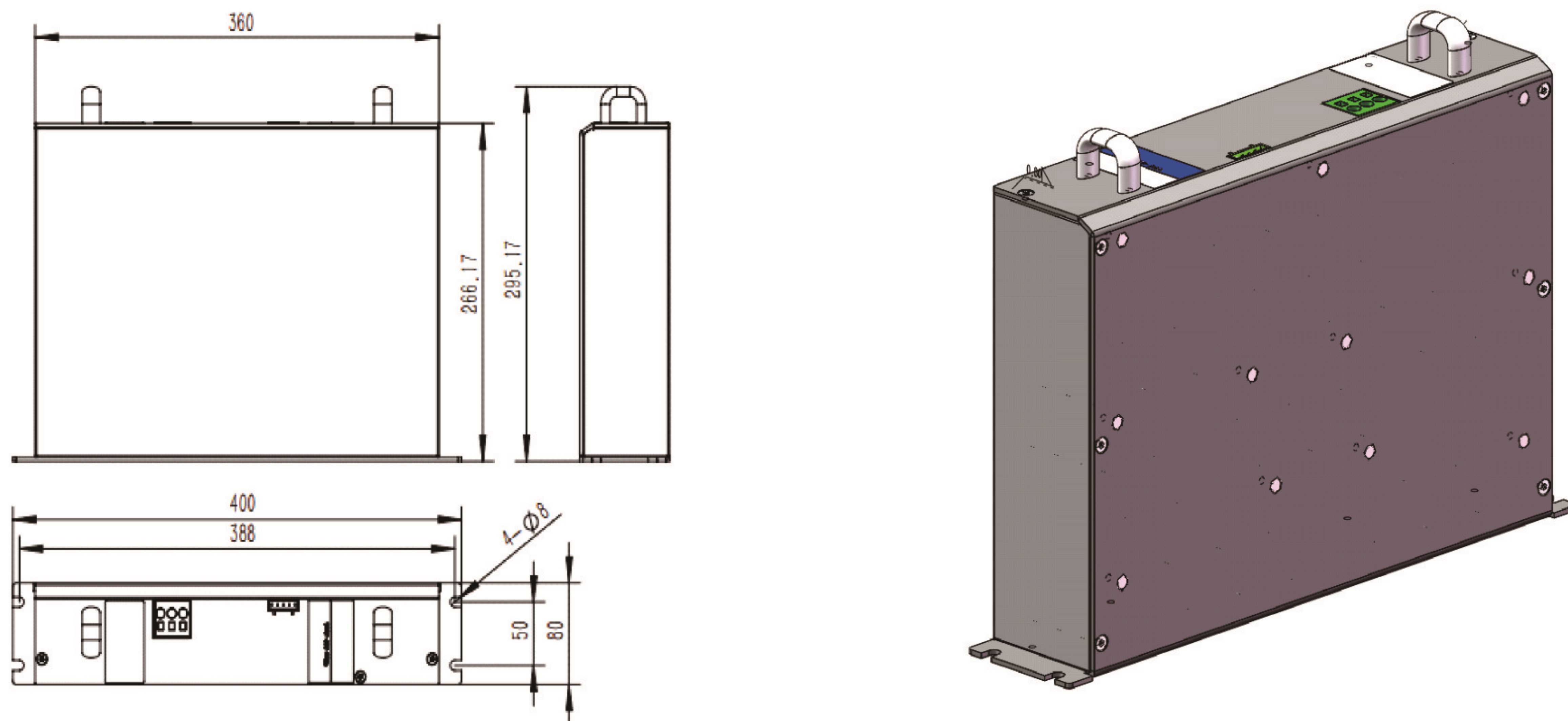

Parameters

Code no.	Rated voltage (V)	Nominal capacity (F)	Dimension(mm)			Internal resistance ESRDC (25°C/mΩ)	Maximum operating current(A)		Maximum peak current (A)	Maximum leakage current (72hrs/mA)	Maximum energy (W.h)	Energy density (W.h/kg)	Power density (KW/kg)
			Length (L)	Width (W)	Height (L)		(ΔT=15°C)	(ΔT=40°C)					
SMD0160R0007PAJZF00	160	7	400	80	295	196	16	27	250	30	28	4.1	2.6

产品介绍

BASIC INTRODUCTION OF SUPER-CAPACITOR

概述

基于公司团队开发的碳基石墨烯复合材料的比表面积远高于商用活性炭，微孔增多，含氧量降低，上述特性均有利于制备高耐压、高容量的双电层电极。所开发的高耐压电解质的电化学窗口高达3.5V。基于此，公司目前已成功开发并量产高性能核心电极材料、电解质和高能量密度EDLC器件，电压平台可达3.0V/3.2V，产品容量为1F~3000F；产品形态涵盖导针型小型单体、焊针型中型单体、激光焊接型大型单体、接受尺寸容量定制化的软包单体和标准模组，并能根据客户要求开发由超级电容与其他储能器件组成的混合储能系统。

公司开发的3.0V EDLC产品在循环寿命、工作环境温度、内阻等性能上与行业2.7V产品相差无几，同比性能远优于业内3.0V产品。基于高电压平台，采用我司单体进行模组（系统）设计时，可使用更少单体数达到相同的电压平台，并具有更高的额定能量，从而减少模组（系统）一次性投入成本。我司单体更高的能量密度和功率密度，使其在某些特殊场景下具有无可替代的优势。

Overview

The Carbon-based graphene composite materials developed by our team can contribute to the preparation of electric double layer electrodes with high withstand voltage and high capacity because of much higher specific surface area than commercial activated carbon, increased proportion of micropore, reduced oxygen content and optimized structure. The electrochemical window of our high voltage electrolyte is as high as 3.5V. Based on these, our company has successfully developed and mass-produced high-performance electrode materials, electrolytes and high-energy-density EDLC devices. Their voltage plateau are 3.0V/3.2V and capacity range is from 1F to 3000F. And our product shape covered guide pin small monomers, welding pin medium monomers, laser welding large monomers, pouch cell which can accept customized size and capacity and capacity and standard modules. Moreover, we can develop combined energy storage systems of supercapacitors and other energy storage devices according to customer requirements.

The performance of our product : 3.0V EDLC is almost the same as that of 2.7V products in the industry in terms of cycle life, working environmental temperature and internal resistance, and is far better than that of 3.0V products in the industry. Based on the high voltage platform, the module (system) design using our monomer can use less monomer to reach the same voltage platform and higher rated energy, thus reducing the one-time cost of the module (system). Besides, our monomer with higher energy density and power density make it have irreplaceable advantages in some special scenarios.